

Quad-MCU "Audio Processing Pipeline" (APP)

4x STM32F7 for audio processing + STM32F7 Discovery for UI

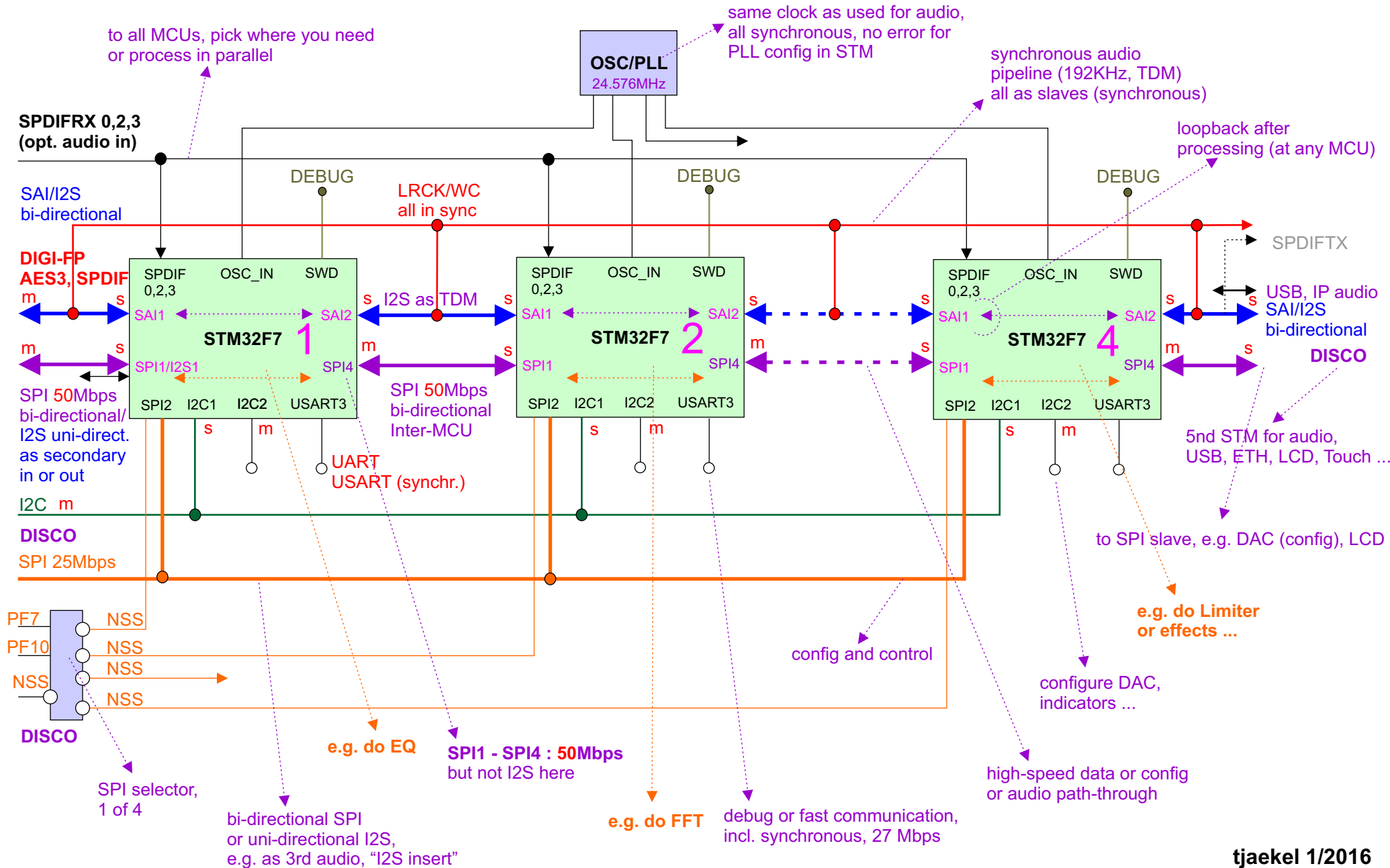

“Lyrebird” Multi-MCU “Audio Processing Pipeline (APP)”

